

Flow Sensor

FFAF178

Part Number

UniFlow



- Highest precision of its class
- Installation in any position
- Measurement independent of flow direction
- Simple operation via the display
- Temperature of the medium: 0 ... 60° C (140° C for 24 hours without current measurement)

wenglor UniFlow flow sensors measure the flow rate of aqueous and oily media in closed piping systems. UniFlow flow sensors are very easy to operate thanks to the integrated display. The highly visible switching status display enables the rapid localization of affected sensors for maintenance processes.

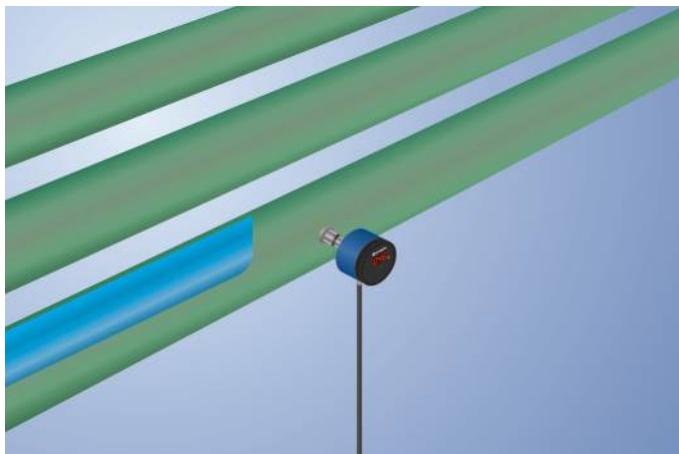

Technical Data

Sensor-specific data	
Measuring Range	15...100 cm/s
Setting Range	20...100 cm/s
Medium	Oil
Measuring error (total)	2 %
MTTFd (EN ISO 13849-1)	1341,35 a
Switching Hysteresis	5 %
Temperature gradient	30 K
Response time in case of temperature jump	10 s
Environmental conditions	
Temperature of medium	0...60 °C
Ambient temperature	-20...70 °C
Pressure Resistance	60 bar
EMC	DIN EN 60947-5-9
Shock resistance per DIN IEC 68-2-27	30 g / 11 ms
Vibration resistance per DIN IEC 60068-2-6	20 g (10...2000 Hz)
Electrical Data	
Supply Voltage	16...32 V DC
Current Consumption (U _b = 24 V)	60 mA
Number of Switching Outputs	2
Switching Output A1	Flow
Switching Output A2	Flow
Response Time	4...15 s
Switching Output/Switching Current	< 250 mA
Switching Output Voltage Drop	< 2 V
Short Circuit Protection	yes
Reverse Polarity Protection	yes
Protection Class	III
Mechanical Data	
Setting Method	Menu
Housing Material	PBT; PC; FKM
Material Control Panel	Polyester
Material in contact with media	1.4435; 1.4404; FKM
Degree of Protection	IP67 *
Connection	M12 × 1; 4-pin
Process Connection	Sealing cone M18 × 1,5
Process Connection Length (PCL)	64 mm
Probe Length (PL)	44 mm
PNP NO	●
Connection Diagram No.	536
Control Panel No.	A03
Suitable Connection Equipment No.	2
Suitable Mounting Technology No.	900 901

* Certified by wenglor

Complementary Products

Software

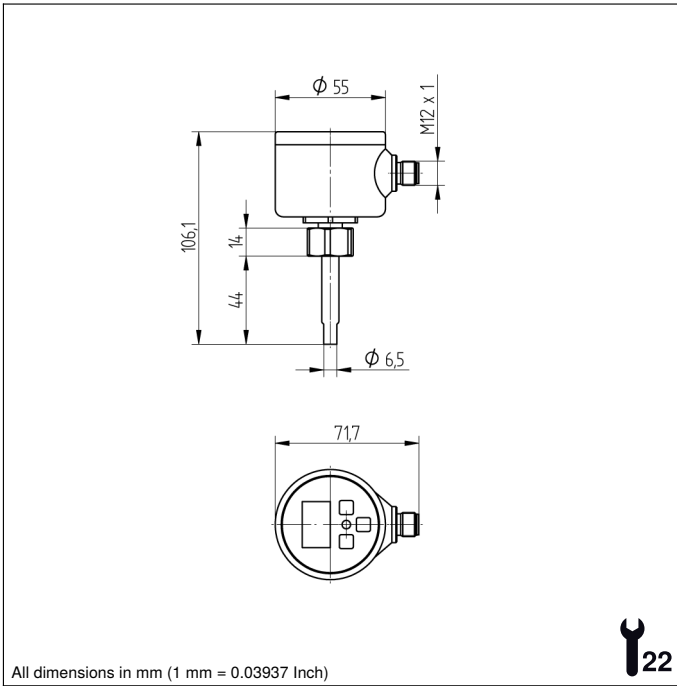

Ctrl. Panel

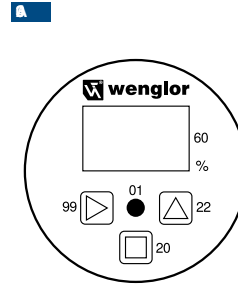

- 01 = Switching Status Indicator
- 20 = Enter key
- 22 = Up key
- 60 = display
- 99 = Right button

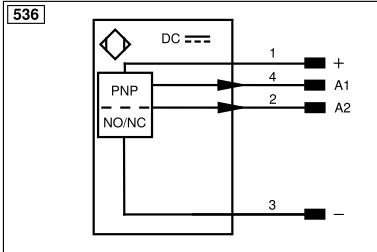

Legend			
+	Supply Voltage +	nc	Not connected
-	Supply Voltage 0 V	U	Test Input
~	Supply Voltage (AC Voltage)	Ü	Test Input inverted
A	Switching Output (NO)	W	Trigger Input
Ā	Switching Output (NC)	W-	Ground for the Trigger Input
V	Contamination/Error Output (NO)	O	Analog Output
ȳ	Contamination/Error Output (NC)	O-	Ground for the Analog Output
E	Input (analog or digital)	BZ	Block Discharge
T	Teach Input	Amv	Valve Output
Z	Time Delay (activation)	a	Valve Control Output +
S	Shielding	b	Valve Control Output 0 V
RxD	Interface Receive Path	SY	Synchronization
TxD	Interface Send Path	SY-	Ground for the Synchronization
RDY	Ready	E+	Receiver-Line
GND	Ground	S+	Emitter-Line
CL	Clock	±	Grounding
E/A	Output/Input programmable	SnR	Switching Distance Reduction
IO-Link		Rx+/-	Ethernet Receive Path
PoE	Power over Ethernet	Tx+/-	Ethernet Send Path
IN	Safety Input	Bus	Interfaces-Bus A(+)/B(-)
OSSD	Safety Output	La	Emitted Light disengageable
Signal	Signal Output	Mag	Magnet activation
Bl_D+/-	Ethernet Gigabit bidirect. data line (A-D)	RES	Input confirmation
ENo RS422	Encoder 0-pulse 0/0 (TTL)	EDM	Contactor Monitoring
PT	Platinum measuring resistor	ENARs422	Encoder A/Ā (TTL)
		ENBrs422	Encoder B/Ĕ (TTL)
		ENA	Encoder A
		ENb	Encoder B
		AMIN	Digital output MIN
		AMAX	Digital output MAX
		Aok	Digital output OK
		SY In	Synchronization In
		SY OUT	Synchronization OUT
		OLT	Brightness output
		M	Maintenance
		rsv	Reserved
		Wire Colors according to DIN IEC 60757	
		BK	Black
		BN	Brown
		RD	Red
		OG	Orange
		YE	Yellow
		GN	Green
		BU	Blue
		VT	Violet
		GY	Grey
		WH	White
		PK	Pink
		GNYE	Green/Yellow