

Vision Sensor

B50S005

Part Number

weQubeVision



- Image processing functions
- MultiCore technology
- Pattern matching

The vision sensor weQubeVision is based on the wenglor MultiCore technology. The functions autofocus, region of interest and tracking ensure optimal object detection. The following image processing modules are available: Dimensional accuracy check, sorting procedures, presence control, object counting, position output, pixel counting, pattern matching, filter options, and statistics evaluation.

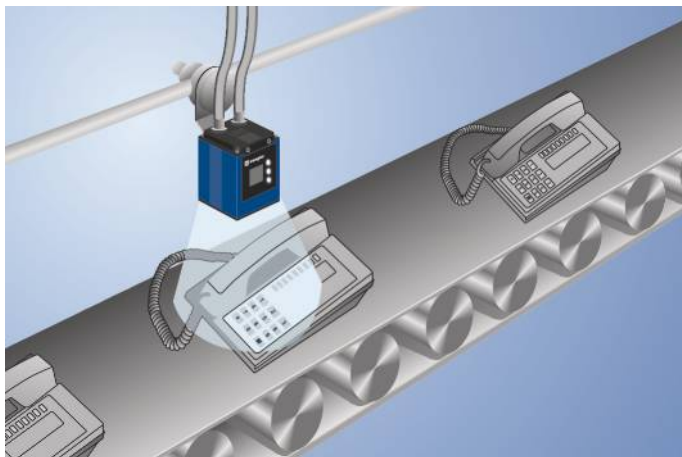

Technical Data

Optical Data	
Working Range	≥ 20 mm
Resolution	736 × 480 Pixel
Resolution	0,35 MP
Focal distance	6,4 mm
Image Chip	monochrome
Image chip size	1/3"
Pixel Size	6 × 6 μm
Light Source	White Light
Optics	Auto-focus
Visual Field	see Table 1
Frame rate (fullframe)	25 fps
Minimum object distance	20 mm
Environmental conditions	
Temperature Range	-25...55 °C*
Atmospheric humidity	5...95%, non-condensing
Electrical Data	
Supply Voltage	18...30 V DC
Current Consumption (U _b = 24 V)	< 200 mA
Inputs/Outputs	6
Switching Output Voltage Drop	< 2,5 V
Switching Output/Switching Current	100 mA
Short Circuit Protection	yes
Reverse Polarity Protection	yes
Interface	RS-232/Ethernet
General protocols	FTP
General protocols	RS-232
General protocols	TCP/IP
General protocols	UDP
Protection Class	III
Mechanical Data	
Housing Material	Aluminum
Degree of Protection	IP67
UL Enclosure Type	1
Connection	M12 × 1; 12-pin
Type of Connection Ethernet	M12 × 1; 8-pin, X-cod.
Optic Cover	Plastic, PMMA, ABS
Safety-relevant Data	
MTTFd (EN ISO 13849-1)	227,7 a
Function	
Presence Check	yes
Pixel Comparison	yes
Reference Image Comparison	yes
Tracking	yes
Object detection	yes
Dimensional accuracy check	yes
Pattern matching	yes
Web server	yes
License package	weQubeVision Standard +

PNP NO

Display brightness may decrease with age. This does not result in any impairment of the sensor function.
 * -25 °C: Ambient conditions should not result in condensation; avoid the formation of ice on the front panel!
 55 °C: Continuous illumination at max. 1% or flash mode at 100% brightness with an exposure time of ≤ 5 ms; may affect the service life of the product.

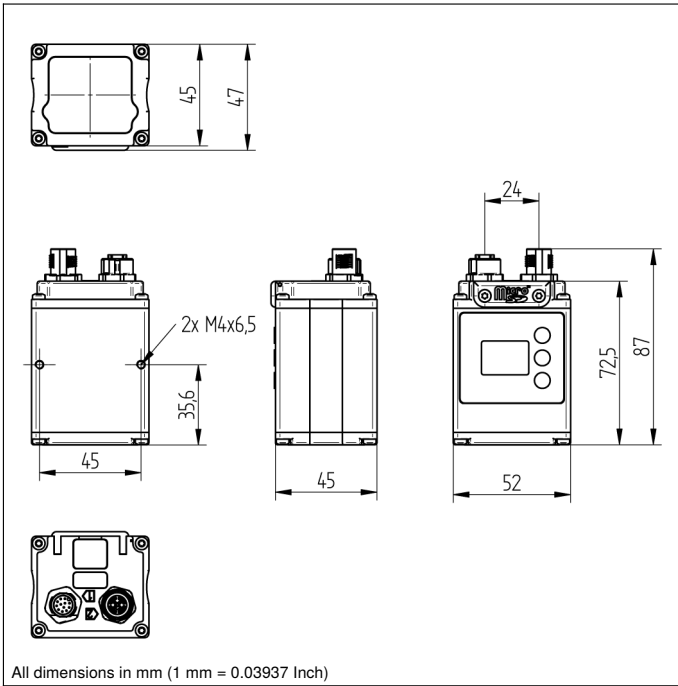

Ctrl. Panel

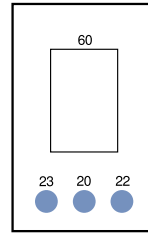
X2

20 = Enter key
22 = Up key
23 = Down key
60 = display

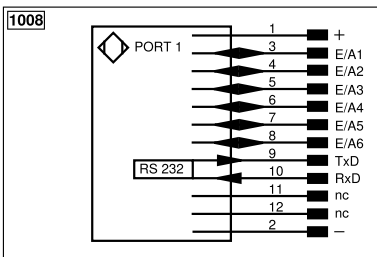

Legend			
+	Supply Voltage +	nc	Not connected
-	Supply Voltage 0 V	U	Test Input
~	Supply Voltage (AC Voltage)	Ü	Test Input inverted
A	Switching Output (NO)	W	Trigger Input
Ā	Switching Output (NC)	W-	Ground for the Trigger Input
V	Contamination/Error Output (NO)	O	Analog Output
ȳ	Contamination/Error Output (NC)	O-	Ground for the Analog Output
E	Input (analog or digital)	BZ	Block Discharge
T	Teach Input	Amv	Valve Output
Z	Time Delay (activation)	a	Valve Control Output +
S	Shielding	b	Valve Control Output 0 V
RxD	Interface Receive Path	SY	Synchronization
TxD	Interface Send Path	SY-	Ground for the Synchronization
RDY	Ready	E+	Receiver-Line
GND	Ground	S+	Emitter-Line
CL	Clock	±	Grounding
E/A	Output/Input programmable	SnR	Switching Distance Reduction
IO-Link		Rx+/-	Ethernet Receive Path
PoE	Power over Ethernet	Tx+/-	Ethernet Send Path
IN	Safety Input	Bus	Interfaces-Bus A(+)/B(-)
OSSD	Safety Output	La	Emitted Light disengageable
Signal	Signal Output	Mag	Magnet activation
BI_D+/-	Ethernet Gigabit bidirect. data line (A-D)	RES	Input confirmation
ENo RS422	Encoder 0-pulse 0/0 (TTL)	EDM	Contactor Monitoring
PT	Platinum measuring resistor	ENARs422	Encoder A/Ā (TTL)
			Wire Colors according to DIN IEC 60757
			BK Black
			BN Brown
			RD Red
			OG Orange
			YE Yellow
			GN Green
			BU Blue
			VT Violet
			GY Grey
			WH White
			PK Pink
			GNYE Green/Yellow

Table 1

Working Distance	20 mm	100 mm	200 mm
Visual Field	9 × 6 mm	65 × 42 mm	134 × 87 mm

